

Series 32 compact cylinders, Tandem and Multi-position versions

Double-acting, magnetic
 \varnothing 25, 40, 63, 100 mm

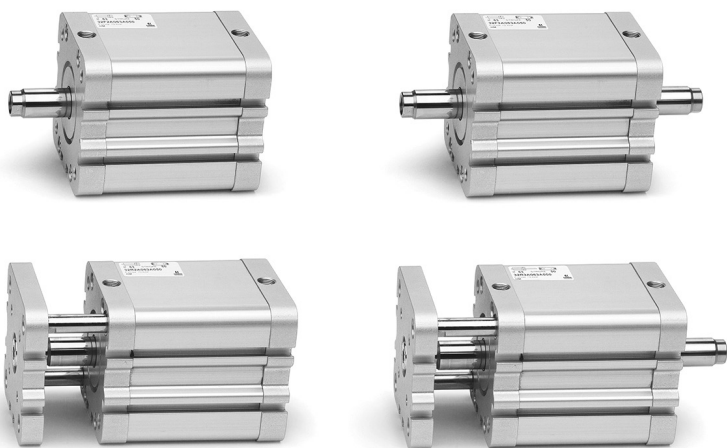

- » In compliance with ISO 21287
- » Compact design
- » Wide range of models available in different diameters

Thanks to their great compactness Series 32 cylinders, Tandem and Multi-position, are suitable to be installed within confined spaces and can be used with the same mounting elements of other standard cylinders DIN/ISO 6431/VDMA 24562 (Series 60/61). The Tandem version enables to obtain up to 2 times the thrust force of a normal cylinder (standard traction force), while the Multi-position version can obtain up to three positions with one cylinder only.

GENERAL DATA

Construction	compact profile
Operation	double-acting, magnetic
Material	body and end-blocks = anodized AL rod = rolled stainless steel AISI 303 piston = anodized AL rod seal, OR end-block and piston seal = PU
Mounting	with threaded holes on the end blocks flange - feet - trunnion
Strokes min. and max. (1)	Series 32F, 32M \varnothing 25 = 5-300 mm (dimension x2)
Multi-position	Series 32F, 32M \varnothing 40 - 63 = 5-400 mm (dimension x2) Series 32F, 32M \varnothing 100 = 5-500 mm (dimension x2)
Strokes min. and max. (1)	Series 32F, 32M \varnothing 25 = 5-80 mm
Tandem	Series 32F, 32M \varnothing 40 - 63 - 100 = 5-100 mm
Operating temperature	0°C ÷ 80°C (with dry air -20°C)
Operating pressure	1 ÷ 10 bar
Fluid	clean air, without lubrication. If lubricated air is used, it is recommended to use oil ISOVG32. Once applied the lubrication should never be interrupted.
Operating speed	10 ÷ 1000 mm/sec (without load)

(1) the minimum stroke for the use of the sensors is 10 mm.

CODING EXAMPLE

32	M	2	A	040	A	050	N	2
-----------	----------	----------	----------	------------	----------	------------	----------	----------

32	SERIES compact magnetic							
M	VERSION M = male rod thread, mounted with rod nut Mod. U F = female rod thread							
2	OPERATION 2 = double-acting						PNEUMATIC SYMBOLS CDPP	
A	MATERIALS A = anodized aluminium profile, end blocks and piston PU seals (rod - OR end block and piston)							
040	BORE 025 = 25 mm 040 = 40 mm 065 = 63 mm 100 = 100 mm						CD5T, CD6T, CD7T CD5T, CD6T, CD7T CD2T, CD3T, CD4T CD5T, CD6T, CD7T	
A	CONSTRUCTION A = standard							
050	STROKE - Tandem stroke in mm - Multi-position X1mm/X2mm. Insert the strokes without the initial 0 (see application scheme)							
N	Tandem and Multi-position							
2	STAGES (for Tandem version only) 2 = 2 stages							

SERIES 32 CYLINDERS - TANDEM AND MULTI-POSITION

PNEUMATIC SYMBOLS

The pneumatic symbols which have been indicated in the CODING EXAMPLE are shown below.

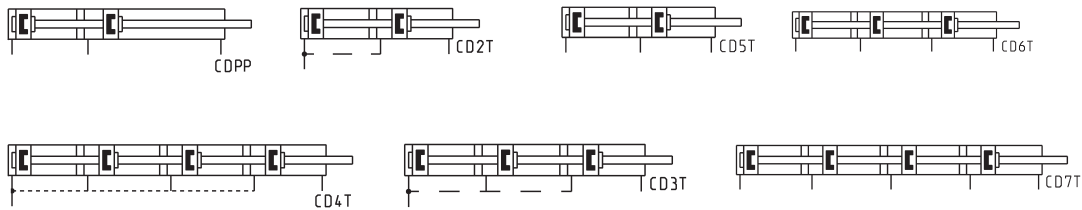

Operation scheme

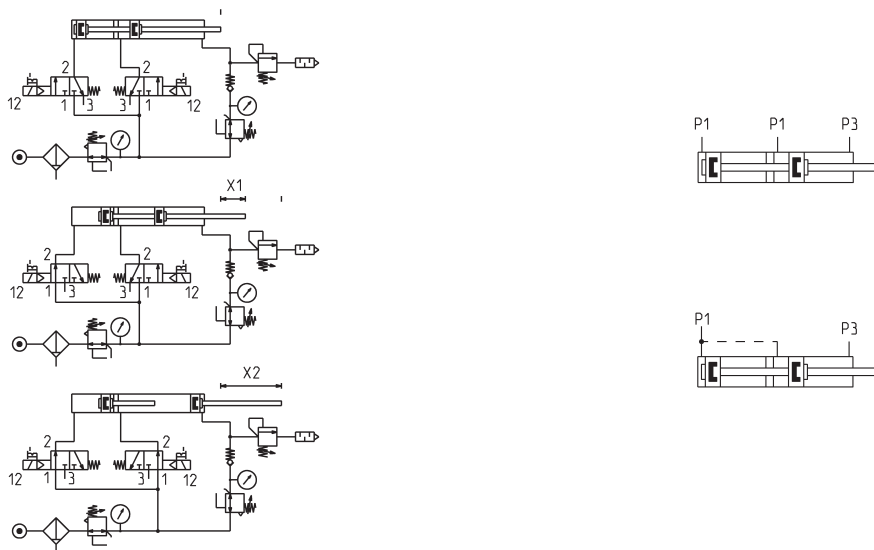

Multi-position - Example: 32M2A040A25/75N
X1 = 25 mm
X2 = 75 mm

Tandem, stroke = 50 mm - Example: 32M2A040A050N2
In order to increase the speed of the rod's return, it is possible to remove the covers from the intermediate end caps and supply the positive chambers from the outside

Tandem cylinders Mod. 32F2A/32M2A...N2



+ = add the stroke
 ++ = add the stroke two times
 1 = Groove for sensor
 2 = Positive stroke
 3 = Negative stroke

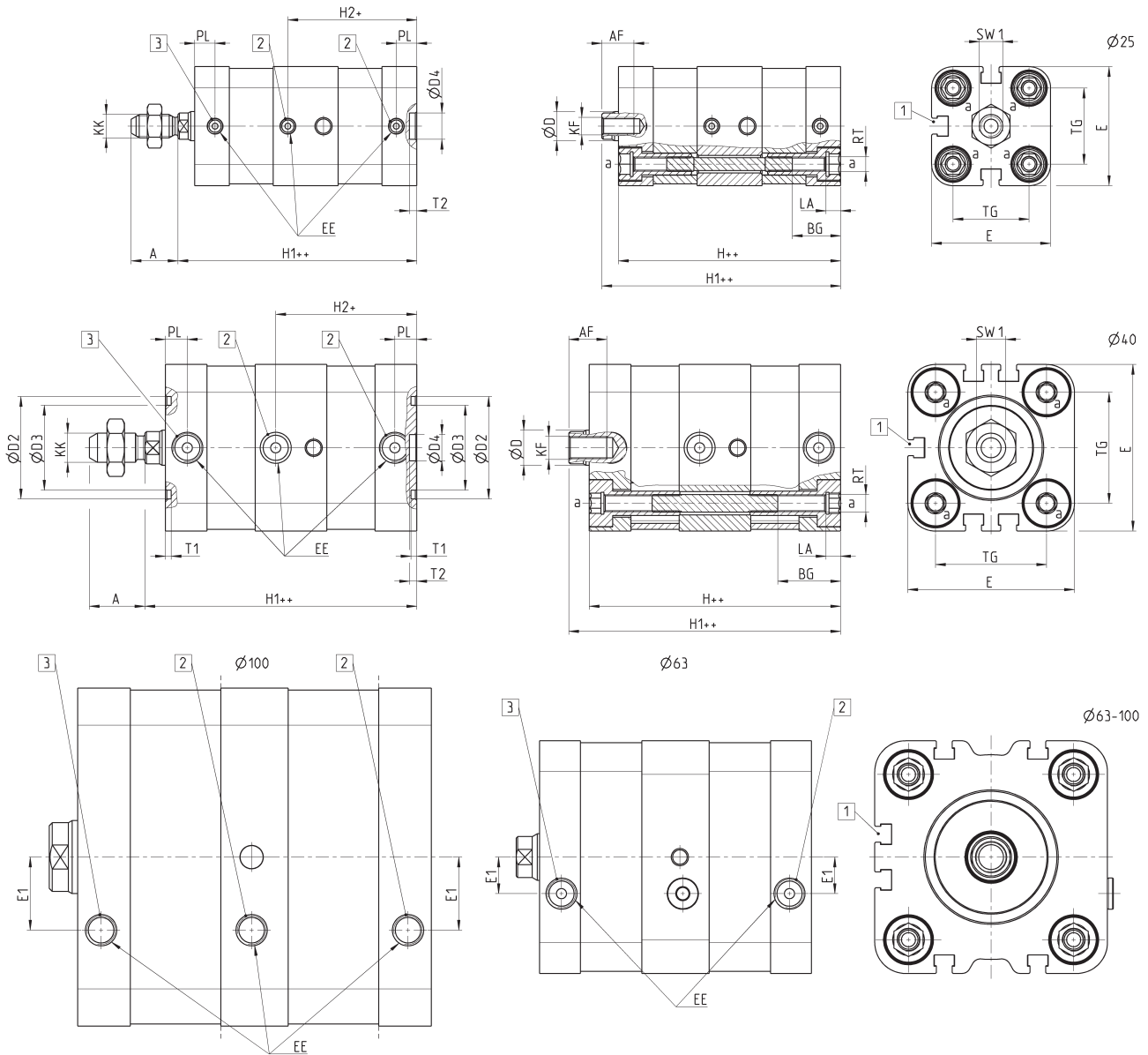

DIMENSIONS																						
\varnothing	A	AF	BG	$\varnothing D$	$\varnothing D2$	$\varnothing D3$	$\varnothing D4$	E	EE	E1	H	H1	H2	KF	KK	LA	PL	RT	SW1	T1	T2	TG
25	16	11	16,5	10	-	-	9	40,7	M5	-	76	81,7	44	M6	M8X1,25	5	7	M5	8	-	2,5	26
40	19	13	21,5	12	35	29	9	57	G1/8	-	86	93	48,2	M8	M10X1,25	5	7,6	M6	10	2	2,5	38
63	22	16	18,5	16	45	39	12	79,6	G1/8	12'5	93	101	-	M10	M12X1,25	6	7,6	M8	13	2	3	56,5
100	28	20	20	25	55	49	12	115,6	G1/8	25	121	130,7	-	M12	M16X1,5	6	8	M10	22	2	3	89

Multi-position cylinders Mod. 32F2A/32M2A...X1/X2N

- 1 = Groove for sensor
- 2 = Positive stroke cylinder 1
- 3 = Positive stroke cylinder 2
- 4 = Negative stroke for both cylinders



X1 = Partial stroke
X2 = Total stroke as operation scheme pag. 1.1.31.2

SERIES 32 CYLINDERS - TANDEM AND MULTI-POSITION

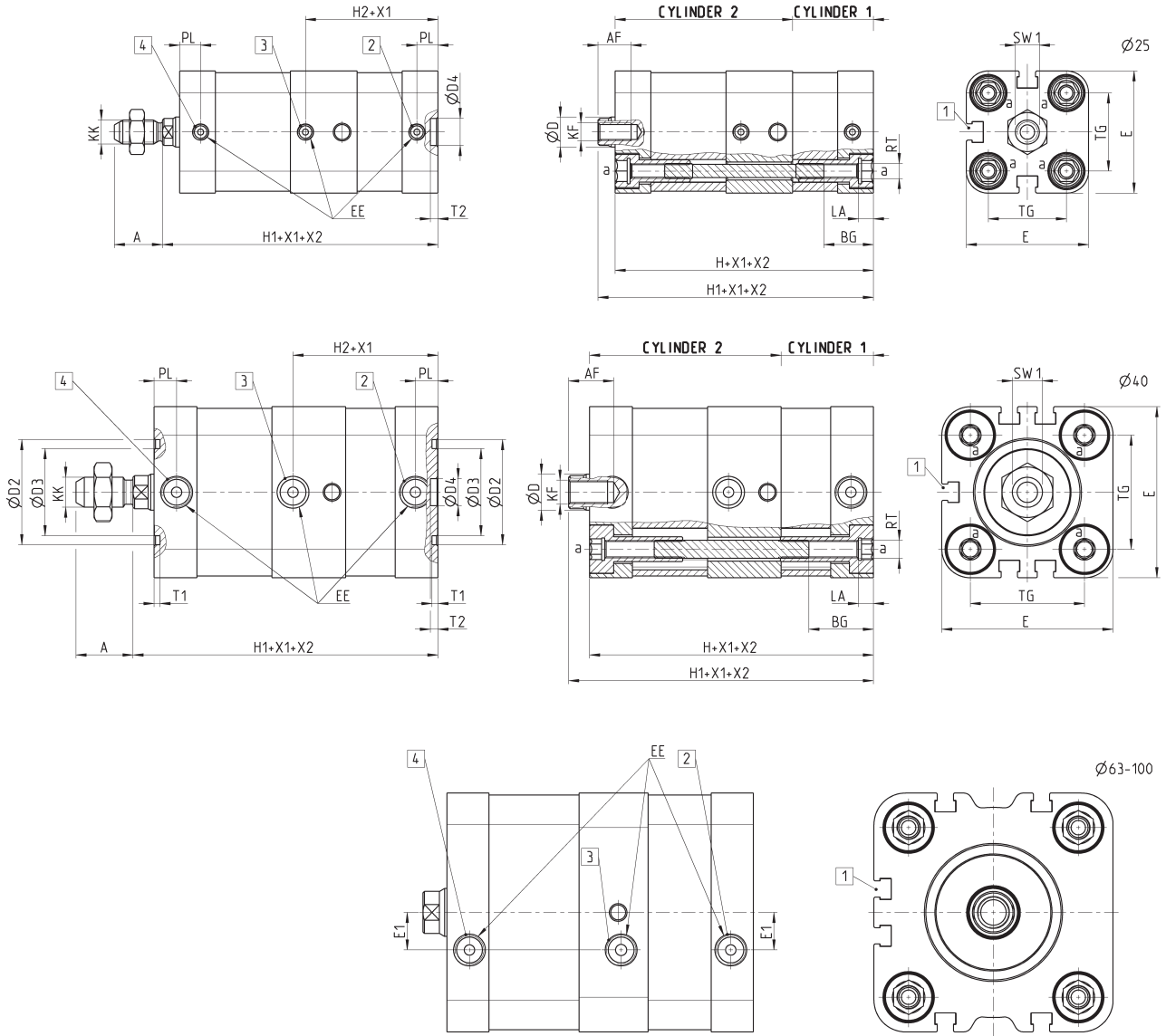

DIMENSIONS																						
Ø	A	AF	BG	ØD	ØD2	ØD3	ØD4	E	EE	E1	H	H1	H2	KF	KK	LA	PL	RT	SW1	T1	T2	TG
25	16	11	16,5	10	-	-	9	40,7	M5	-	76	81,7	44	M6	M8X1,25	5	7	M5	8	-	2,5	26
40	19	13	21,5	12	35	29	9	57	G1/8	-	86	93	48,2	M8	M10X1,25	5	7,6	M6	10	2	2,5	38
63	22	16	18,5	16	45	39	12	79,6	G1/8	12,5	93	101	44	M10	M12X1,25	6	7,6	M8	13	2	3	56,5
100	28	20	20	25	55	49	12	115,6	G1/8	25	121	130,7	60,5	M12	M16X1,5	6	8	M10	22	2	3	89