

# Series VNV check valves

These check valves are mainly used on vacuum gripper systems containing multiple suction pads in order to shut off individual suction pads which are not covered.

Thread size M5, G1/8, G1/4, G3/8, G1/2.

» Enable the de-activation of suction pads not in contact with the workpiece, thus makes it possible to create more versatile "multi use" gripping system.

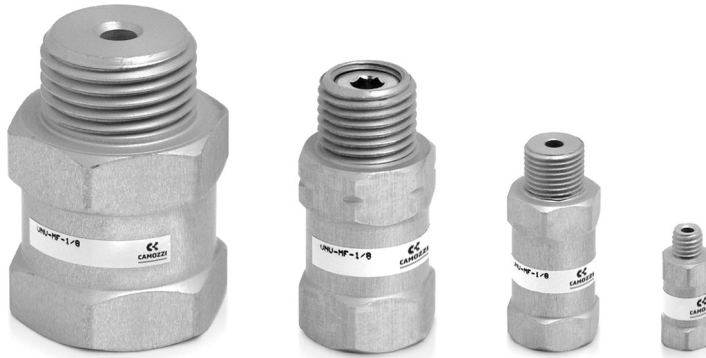

The check valves Series VNV are mainly used on vacuum gripper systems containing multiple suction pads in order to shut off individual suction pads which are not covered or accidentally pulled away from the workpiece. In this way the gripper system can operate correctly maintaining the vacuum level necessary for the application.

#### Applications:

- Handling objects with different shape and dimensions with the same gripping system

## GENERAL DATA

- Description**
- ball seat valve with fixed bypass function
  - aluminium body with internal elements in brass
  - integrated dirt filter

## TECHNICAL DATA

Max required suction flow and according different pressures

Mod.	- 0,3 bar (m <sup>3</sup> /h)	- 0,3 bar (l/min)	- 0,6 bar (m <sup>3</sup> /h)	- 0,6 bar (l/min)	Max flow (m <sup>3</sup> /h)	Max flow (l/min)	Weight (g)
VNV-MF-M5	0.12	2	0.22	3.7	2.3	38,3	2.2
VNV-MF-1/8	0.22	3.7	0.43	7.2	15.7	261.7	11.2
VNV-MF-1/4	0.24	4	0.47	7.8	21.9	365	17.5
VNV-MF-3/8	0.44	7.3	0.48	8	35.4	590	30.3
VNV-MF-1/2	0.7	11.7	1.4	23.3	37	616.7	47.4
VNV-FM-1/8	0.22	3.7	0.43	7.2	15.7	261.7	11.2
VNV-FM-1/4	0.24	4	0.47	7.8	21.9	365	17.5
VNV-FM-1/2	0.7	11.7	1.4	23.3	37	616.7	47.4

## CODING EXAMPLE

<b>VNV</b>	-	<b>MF</b>	-	<b>M5</b>
------------	---	-----------	---	-----------

<b>VNV</b>	SERIES VNV = Check valve
<b>MF</b>	THREAD VERSION MF= G1 male / G2 female FM = G1 female / G2 male
<b>M5</b>	THREAD M5 = M5 1/8 = G1/8 1/4 = G1/4 3/8 = G3/8 (MF version only) 1/2 = G1/2

### VNV from M5 to G1/2, Male - Female thread



Drawing note:  
A = air flow direction during suction

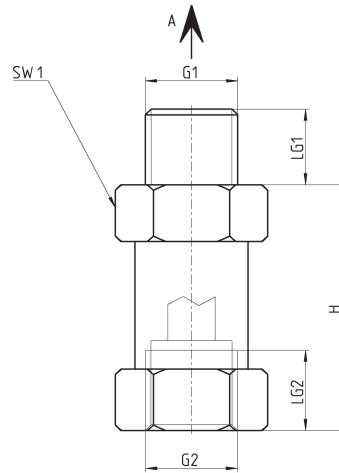
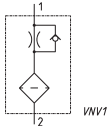

Table note:  
\* M = Male thread  
\* F = Female thread



DIMENSIONS							
Mod.	G1*	G2*	H	LG1	LG2	SW1	
VNV-MF-M5	M 5 M	M 5 F	15.5	4.5	4.5	8	
VNV-MF-1/8	G1/8 M	G1/8 F	26	8.5	8	14	
VNV-MF-1/4	G1/4 M	G1/4 F	26	11	10	17	
VNV-MF-3/8	G3/8 M	G3/8 F	29	10	12	22	
VNV-MF-1/2	G1/2 M	G1/2 F	29	14	12	27	

### VNV from G1/8 to G1/2 - Female - Male thread



Drawing note:  
A = air flow direction during suction

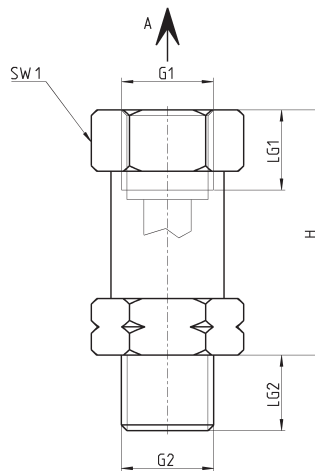
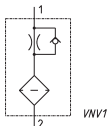

Table note:  
\* M = Male thread  
\* F = Female thread



DIMENSIONS							
Mod.	G1*	G2*	H	LG1	LG2	SW1	
VNV-FM-1/8	G1/8 F	G1/8 M	26	8	8,5	14	
VNV-FM-1/4	G1/4 F	G1/4 M	26	10	11	17	
VNV-FM-1/2	G1/2 F	G1/2 M	29	12	14	27	